



AB 6100 Submersible Fluoride ISE sensor for Acid Service and Fluoride WWT applications; Integral Pre-amplifier with Braid Reinforced Blue Cable



ABGR 8XX0 Submersible Ion Selective Sensor with WPB Seal; Rugged Industrial Thick Large Surface Organic PVC Membrane; 4 each "GR" tines



ABX 6100H-1000-20-TL-WPIT/5 Immersion Fluoride Ion Selective Sensor; WPIT seal; without preamp configuration



AB 8XX0 Twist Lock Quick Disconnect Inline Silver Halide Series Ion Selective ISE sensor with no preamplifier

® RADEL registered trademarks of SOLVAY
® KYNAR registered trademarks of ARKEMA

® Viton and Kalrez are registered trademarks of DuPont. Simriz is a registered trademark of Freudenberg Sealing Technologies (SIMRIT).

Rugged Industrial Grade Ion Selective (ISE) Sensors for Continuous Inline, Immersion, Submersible, Sanitary & HOT-TAP Valve Retractable Field Measurements:

ION MEASUREMENTS AVAILABLE:

- Unique rugged industrial grade fluoride (F⁻) monocrystal sensing element is linear across a very wide range of concentrations (up to saturation and linear to 2%, a.k.a. 20,000ppm) as well as down to the ppb levels
- Solid-state silver halide based ion selective sensors for measurement of chloride (Cl⁻), bromide (Br⁻), iodide (I⁻), cyanide (CN⁻) and silver (Ag⁺).
- PVC membrane based ion selective sensors for measurement of ammonium (NH₄⁺), sodium (Na⁺), calcium (Ca²⁺), lithium (Li⁺), chloride (Cl⁻), nitrate (NO₃⁻), nitrite (NO₂⁻) and perchlorate (ClO₄⁻)

CORE ION SELECTIVE SENSOR FEATURES:

- Best reference service lifetime in process industry through proprietary, novel, non-porous, cross-linked, conductive polymer technology; Available in double junction (standard) or triple junction (optional "TJ") configuration.
- Large surface area industrial grade PVC membrane for measurement of ammonium (NH₄⁺), sodium (Na⁺), calcium (Ca²⁺), lithium (Li⁺), chloride (Cl⁻), nitrate (NO₃⁻), nitrite (NO₂⁻) and perchlorate (ClO₄⁻) are solvent bound to PVC electrode for excellent mechanical integrity during long term use and for aggressive field process installations.
- Fluoride (F⁻) ion selective sensing elements offers nearly no interfering ions and excellent linearity across a very wide range of use. Available for use in application from 0-12 pH ranges with AB 6100 model or 5.5 to 9.5 with AB 8100, AB 5100 or AB 6100H models.
- Solid-state silver halide type ion sensing elements for measurement of chloride (Cl⁻), bromide (Br⁻), iodide (I⁻), cyanide (CN⁻) and silver (Ag⁺) are designed for use at elevated temperatures due to unique design and manufacturing scheme. Very large surface area and thick crystals allow for repeated repolishing as may be required for extended sensor service lifetime.
- Available in no protective tines to minimize air bubbles for inline low-flow type installations. Also configuration are also offered in 2 each ("GRO") or 4 each ("GR") protective tine configurations recommended for immersion and submersible installations.
- All ion selective sensors come standard with Pt1000 temperature compensation element. ACCU-TEMP option for fast temperature response is recommended for inline and sanitary installation styles where only the sensor tip is in contact with the process solution.
- Selected optional features include ACCU-TEMP Fast TC ("X") which is critical for accurate temperature compensation of inline measurements. The braid reinforced thick PVC jacketed blue preamplifier cable ("BL") is available to best results in high noise environments or for installation where mechanical wear on cable may be a potential installation issue.



CORE ION SELECTIVE SENSOR FEATURES (CONTINUED):

- Ion selective sensors in base without integral preamplifier configuration (~ can be used for installation up to 35 feet (~10 meters) maximum. The leads must be wired directly into the ISE transmitter with this configuration and cannot be bridged. ISE probes without preamplifier should be kept to a cable length of 20 feet (6 meters) whenever possible. For longer cable runs or to bridge the signal use the with integral preamplifier configuration.
- ISE sensors are available with integral conventional analog preamplifier to support cable lengths up to 100 meters (330 feet) as well as Q7M/Q7F NEMA 6P rated snap connector system (see more below). ISE sensors with integral preamplifiers can have their tinned leads bridges across terminal strips in a waterproof J-box enclosure assembly).
- End of cable terminations are tinned leads standard for both with and without integral preamplifier configurations
- **Quick disconnect IP67 & NEMA 6P rated** waterproof and corrosion resistant **Q7M/Q7F snap connector** option is available for ion selective (ISE) sensors with integral preamplifiers.

FIELD INSTALLATION CONFIGURATIONS SUPPORTED & ISE SENSOR OPTIONS:

- Quick-Disconnect Twist Lock Bayonet Style Receptacles allow for easy and fast insertion and removal from process line for calibration and cleaning. Standard in KYNAR® (Poly-Vinylidene-Fluoride, PVDF) material of construction with stainless steel locking pins.
- The 6XX0 series ion selective sensor can be installed into inline low-flow panel assemblies as well immersed into a tank using a suitable standpipe or guiderod. It is submersible when a waterproofing option is invoked even without the use of an immersion tube to seal the rear threads.
- Sanitary TRI-CLOVER style installations are supported using the 5XX0 series ion selective sensors employing the same 316SS hardware as for the sanitary pH & ORP sensors. See the pH & ORP sensor configuration page for details about the mating sanitary sensor holder with welded 1.5", 2.0" or 2.5" TRI-CLOVER flange.
- HOT-TAP valve retractable style installations are also supported using the 5XX0 series ion selective sensors employing the same 316SS retraction hardware assemblies as for the valve retractable pH & ORP sensors.
- Double O-ring design ensures secure seal during operation with twist lock quick disconnect bayonet (8XX0) type ISE sensors and sanitary/HOT-TAP style ISE sensors (5XX0).
 - Standard material of construction is Viton®-75, with CV75, Simriz® 485 and Kalrez® 4079 Optional.
- Back of sensor can be sealed with waterproofing option for use in immersion or submersible type applications as well as for inline use. For immersion and submersible installation it is recommended to add a protective tines option ("GR" or "GRO") to the 8XX0 twist lock and 5XX0 sanitary/HOT-TAP ISE sensors as well as a suitable waterproofing option.
- Available options for the ion selective sensors in the 6XX0 series immersion/submersible, 8XX0 inline twist lock quick disconnect & 5XX0 sensors for sanitary / HOT-TAP installations detailed on ISE sensors options section.
- Extensive ion selective addendum support documentation is provided to ensure best practice field installation of the ion measurement systems using ASTI industrial ion selective sensors (review prior to purchase & commissioning).

MATERIALS OF CONSTRUCTION & CORE TECHNICAL SPECIFICATIONS:

- Most ISE sensor with PVC type ion sensing elements (ammonium, calcium, sodium, lithium, ...etc) have a temperature range of +5 to +40 °C (41 to 104 °F) with a pressure of 1 to 10 psig (6.9 to 69 kPag)
 - Some PVC type ion sensing elements available in a special style to support use up to +50 °C (+122 °F). Inquire to factory if your inline ISE application will be over +40 °C to see if this condition can be accommodated.

- Most ISE sensors with solid-state ion sensing element (fluoride, chloride, bromide, iodide, cyanide, ..etc) have a temp range of +5 to +50 degree Celsius (41 to 104 degrees Fahrenheit) with a pressure of 1 to 20 psig (6.9 to 138 kPag)
 - Special AB 6100 fluoride ISE sensor support up to 70 degrees Celsius (158 degrees Fahrenheit) continuous use
- Sensor body housing material of construction is rugged RADEL® (Poly-Phenyl-Sulfone, PPSU) for all ISE sensor configuration. Visit the ion selective (ISE) sensor configuration section to view information on material of construction for ISE sensors and dimensional details for ISE sensor and mating installation hardware including all available physical installation configurations and thermoplastic body materials of construction
- The standard material of construction for the support matrix of the solid-state non-porous conductive polymer is high-density poly-ethylene (HDPE) to ensure the most accurate reading possible.
 - HDPE material of construction for the primary junction support supports the max 70 degrees Celsius max temperature condition possible in many acid etching processes for metal, glass and silicone wafer etching using the special AB 6100 special fluoride ISE sensor
- KYNAR® (Poly-Vinylidene-Fluoride, PVDF) material of construction for the primary junction support matrix offered on selected ISE probes for heavy industrial service applications to maximize the sensor lifetime, particularly in the presence of various dissolved gases and other intrusive fouling constituents.

**Close-Up Photos of Selected Inline Twist Lock & Submersible Ion Selective Sensors
For Visualization of Available Configurations & Options for ISE Industrial Sensors**



** AB 6100 Industrial Fluoride ISE sensor for use in acid etching & fluoride WWTP*

** AB 8100 Fluoride ISE Sensor for measurement in neutral pH conditions*

** ABGR 8410 Ammonium ISE Sensor available in standard & ultalow type membrane configurations*

** AB 6410 Immersion Ammonium ISE Sensor with WPA sealing for use in submersible installation with standpipes*

** Solid-state ion selective sensor with large surface industrial sensing element*

** Unique Special Sealing Cap allows for continuous use in strong acid conditions*

** Double O-ring seals ensure secure leak-proof process connection (Viton Standard with Kalrez Optional)*

** Thick "GR" 4 each protective tines and WPB sealing option invoked for fully submersible installation into process tanks*

** Large surface rugged industrial grade ammonium ion sensing membrane is suitable for aggressive field service*

** Flush no guard configuration ideal for inline installation to minimize fouling*

** WPH sealing installed for fully submersible installation use*

** Industrial grade fluoride sensing element & large surface solid-state reference system*

** Solid-state type ISE sensors available for measurement of chloride, bromide, iodide, cyanide & silver ions*

SELECTED AMMONIUM (NH₄⁺) ISE SENSORS APPLICATIONS:

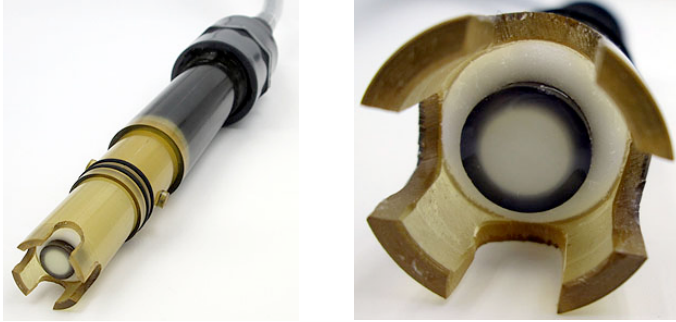

THE ONLY AMMONIUM (NH₄⁺) ion selective sensor that can be:

- Used in heavy industrial process and wastewater treatment system as well as municipal measurements
- Measurements up to saturated ammonium levels
- Operate continuous at temperature up to 50 degrees Celsius for selected ions
- Fully submersible without the use of any standpipe or guiderod (a.k.a. immersion tubes)
 - **Case Study # 7** for total ammonium determination for industrial wastewater compliance measurements.
 - **Case Study # 17** for free ammonium ion monitoring in municipal WWTP aeration basins
 - **Case Study # 18** Free Ammonia (NH₃-N) and total nitrogen monitoring for municipal water districts using chloramination as a part of the sterilization process
 - **Case Study # 19** Ammonium ISE measurement in the presence of potassium and nitrate ion measurement in the presence of chloride with highly selective novel membranes
- The industrial ammonium ion selective sensors in the AB 6410 (3/4"-1" MNPT), AB 8410 (1" MNPT Twist Lock) or AB 5410 (Sanitary or HOT-TAP) together with the a suitable mating dissolved ammonia gas resistant pH sensor can be used to compute the total unbound ammonia species (see graph linked below for visualization):
 - **Total Ammonia** (NH₃-N, or total ammonia as nitrogen)

SELECTED FLUORIDE (F⁻) ISE SENSORS APPLICATIONS:



THE ONLY FLUORIDE (F⁻) ion selective sensor that can be:

- Used in strong acid fluoride etching service at elevated temperatures up to 70 degrees Celsius
- Undergo strong acid cleaning to remove calcium and silicate deposits
- Suitable for measurement in acid fluoride metal etching processes or fluoride wastewater treatment systems for remediation of such etching systems
- Ready for immersion installation standard or fully submersible with insertion tube or waterproofing option invoked.
 - See **AB 6100 specification sheet** for details about the model that is suited for such acid service process and cleaning conditions.
 - See **Case Study # 21** for a detailed description of the specific features and technical advantages that enable far superior service lifetime for the AB 6100 fluoride ISE sensor for these metal etching and fluoride wastewater treatment (WWTP) type applications.
 - See **Case Study # 6** for an example of the use of the AB 6100 fluoride ion selective directly in the acid process media for metal can etching at low pH and elevated temperatures up to 70 degrees Celsius
- The acid service resistant AB 6100 fluoride ion selective sensor together with the X4XX series HF resistant pH sensor can be used to compute the total unbound fluoride species (see graph linked below for visualization):
 - **Total Fluoride** (Total HF, or unreacted fluoride species)

OTHER PVC TYPE ISE SENSOR APPLICATIONS:



- **Calcium** (Ca^{2+}) ion selective sensors for determined of ionized free unbound calcium levels to determine the state of the water softeners to automate regeneration as well as a proxy for the total water hardness.
 - See [Case Study # 15](#) for an example of this use.
- **Chloride** (Cl^-) for high level chloride measurements up to saturation. Whereas the solid-state chloride ISE probe is most well suited for low level measurements (max 350 ppm continuous), the PVC based ion selective sensor does not suffer from measurement at high concentration up to saturation.
- **Lithium** (Li^+) typically for nuclear or research applications uses. Include ultralow detection version for trace analysis.
- **Nitrate** (NO_3^-) and **Nitrite** (NO_2^-) for monitoring of nitrate influent load as well as denitrification systems. Also used for blending operations with potable water to ensure compliance with max nitrate as nitrogen ($\text{NO}_3\text{-N}$) levels. Photo above shows the fully submersible nitrate ion selective sensor assembly with integral waterproofing "B" sealing option in the without preamplifier configuration.
- **Perchlorate** (ClO_4^-) primarily for environmental detection at or near rocket fuel manufacturing facilities.
- **Sodium** (Na^+) is measured in black & white liquor (bleach plants) at pulp mills. Sodium can be measured up to saturation with special calibration schemes.



INDUSTRY LEADING FLUORIDE ISE SENSORS for process control and monitoring of:

- Fluoridation in potable water municipal plants
- Compliance measurements for fluoride discharge levels from industrial processes.
- Convenient twist lock quick disconnect bayonet installation style for easy removal for cleaning, calibration and replacement
- Flush inline installation minimizing flow induced kinetic potential for the most stable readings possible
 - See [AB 8100 specification sheet](#) for details about the inline twist lock fluoride ISE sensor
 - See [Case Study # 13](#) for fluoride ISE sensor for municipal fluoridation monitoring & control

OTHER SOLID-STATE TYPE ISE SENSORS APPLICATIONS:

- **Bromide** (Br^-) and **Iodide** (I^-) are commonly used for tracer environmental applications to monitor water distribution pathways.
- **Chloride** (Cl^-) for low-level trace measurements in clean water applications. Often combined with measurement of the common major counter cation sodium and/or conductivity measurements used as a proxy for the total dissolved solids.
- **Cyanide** (CN^-) is most measured for environmental compliance in sensitive areas to ensure that the SO_x or H_2O_2 destruction process is working normally. Often a pH adjustment must be performed inline and some special calibration and installation schemes employed.
- **Silver** (Ag^+) for sterilization monitoring applications most typically for hospital water supplies. In some cases cupric (Cu^{++}) divalent copper ions can also be monitored with special calibration schemes and setups.

DIMENSIONAL DRAWINGS FOR ION SELECTIVE SENSORS

3/4"-1" MNPT INLINE, IMMERSION & SUBMERSIBLE SERIES SENSORS DIMENSIONAL DRAWING

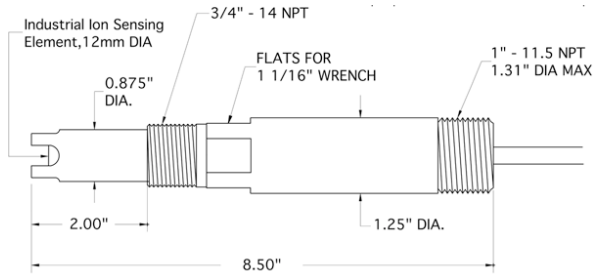

3/4"-1" MNPT Ion Selective (ISE) Sensor 6XX0 Series Dimensional Drawing 6-ISE

AB 6100H Fluoride (F⁻)
 AB 6110 Chloride (Cl⁻)
 AB 6130 Bromide (Br⁻)
 AB 6140 Iodide (I⁻)
 AB 6160 Cyanide (CN⁻)
 AB 6170 Silver (Ag⁺)

AB 6410 Ammonium (NH₄⁺)
 AB 6430 Sodium (Na⁺)
 AB 6440 Calcium (Ca²⁺)
 AB 6480 Perchlorate (ClO₄⁻)
 AB 6490 Lithium (Li⁺)
 AB 6610 Chloride (Cl⁻)
 AB 6810 Nitrate (NO₃⁻) & AB 6820 Nitrite(NO₂⁻)

1" MNPT TWIST LOCK QUICK DISCONNECT BAYONET STYLE INLINE SERIES SENSOR DRAWING

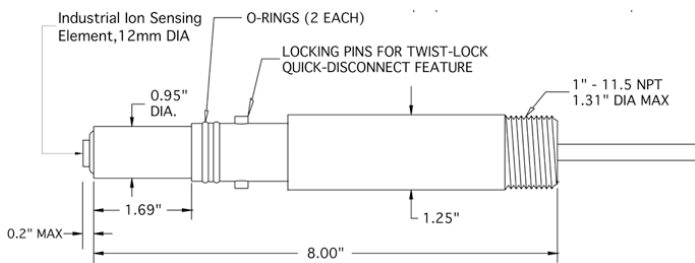

1" MNPT Twist Lock Ion Selective (ISE) Sensor 8XX0 Series Dimensional Drawing 8-ISE

AB 8100 Fluoride (F⁻)
 AB 8110 Chloride (Cl⁻)
 AB 8130 Bromide (Br⁻)
 AB 8140 Iodide (I⁻)
 AB 8160 Cyanide (CN⁻)
 AB 8170 Silver (Ag⁺)

AB 8410 Ammonium (NH₄⁺)
 AB 8430 Sodium (Na⁺)
 AB 8440 Calcium (Ca²⁺)
 AB 8480 Perchlorate (ClO₄⁻)
 AB 8490 Lithium (Li⁺)
 AB 8610 Chloride (Cl⁻)
 AB 8810 Nitrate (NO₃⁻) & AB 8820 Nitrite(NO₂⁻)

1"-1.25" MNPT IMMERSION & SUBMERSIBLE SERIES SENSORS DIMENSIONAL DRAWING

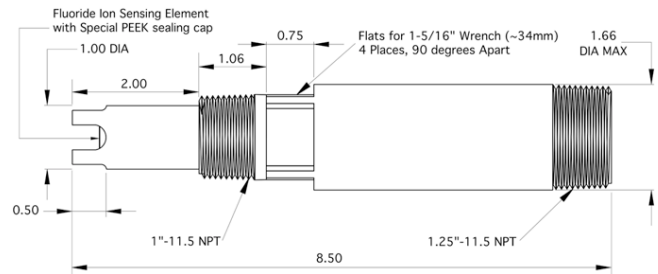

1.00"-1.25" MNPT AB 6100 Special Fluoride Ion Selective (ISE) Sensor Dimensional Drawing F-1-ISE

AB 6100 Special Fluoride (F⁻) Ion Selective Sensor is the ONLY MODEL SUITABLE FOR

- Use in Acid Etching Process Media Service Conditions at Elevated Temperatures or
- Applications requiring strong acid cleaning to remove fouling from sensor

Inquire to ASTI factory for any fluoride ion measurement to determine if the special AB 6100 is required for your desired field measurement.

3/4" MNPT SANITARY & HOT-TAP STYLE SERIES SENSOR DRAWING

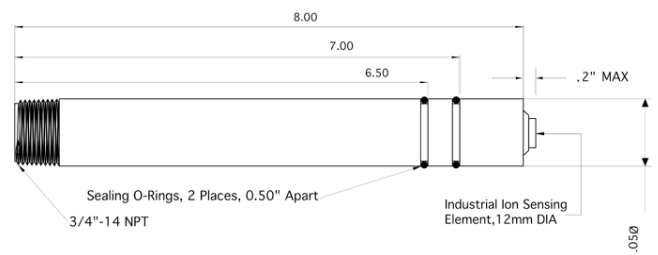

3/4" MNPT Sanitary & HOT-TAP Ion Selective (ISE) Sensor 5XX0 Series Dimensional Drawing 5-ISE

AB 5100 Fluoride (F⁻)
 AB 5110 Chloride (Cl⁻)
 AB 5130 Bromide (Br⁻)
 AB 5140 Iodide (I⁻)
 AB 5160 Cyanide (CN⁻)
 AB 5170 Silver (Ag⁺)

AB 5410 Ammonium (NH₄⁺)
 AB 5430 Sodium (Na⁺)
 AB 5440 Calcium (Ca²⁺)
 AB 5480 Perchlorate (ClO₄⁻)
 AB 5490 Lithium (Li⁺)
 AB 5610 Chloride (Cl⁻)
 AB 5810 Nitrate (NO₃⁻) & AB 5820 Nitrite(NO₂⁻)

REVISION HISTORY		
REV	DESCRIPTION	DATE

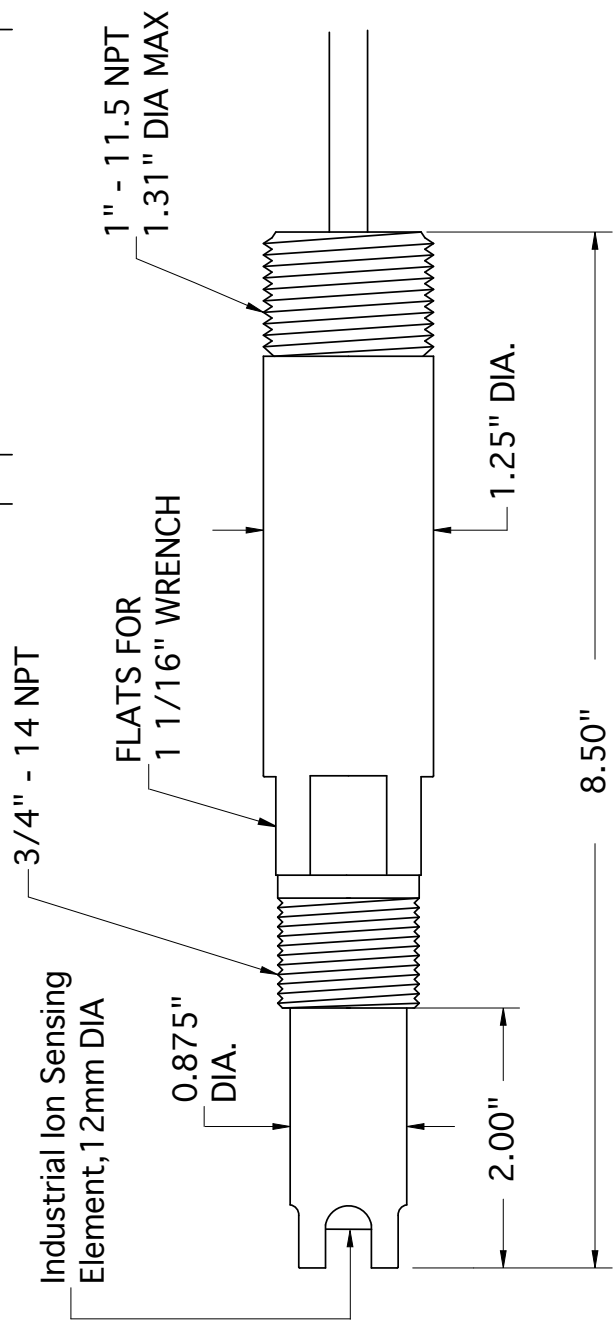

NOTES

- All dimensions are in inches, unless otherwise indicated with tolerances as detailed below
- Sensor body material of construction is RADEL for all 6XX0 series ion selective (ISE) models
- Drawing shown in the standard with protective tines configuration (4 places, 90 degrees apart). The 2 protective tines only "GRO" configuration (2 places, 180 degrees apart) is optional.
- In the alternate without tines configuration ("NG") the sensor body is exactly 8.0 inches in length. The max displacement for Ion Sensing Element is 0.2" yielding a max insertion depth of 1.7 inches past threads & overall max length of 8.2 inches.
- Do not use any sensor beyond the factory defined maximum temperature or pressure rating.

ASTI Advanced Sensor Technologies U.S.A.
Website: <http://www.astisensor.com>

TITLE		3/4" - 1" MNPT Inline / Immersion / Submersible	
PROJECT	IMMERSION	DRAWING NO.	6-ISE Ion Selective Sensor
SIZE	B	REV	/
SCALE	Not to Scale	MODEL	6XX0
SHEET		1	OF 1

3

2

1

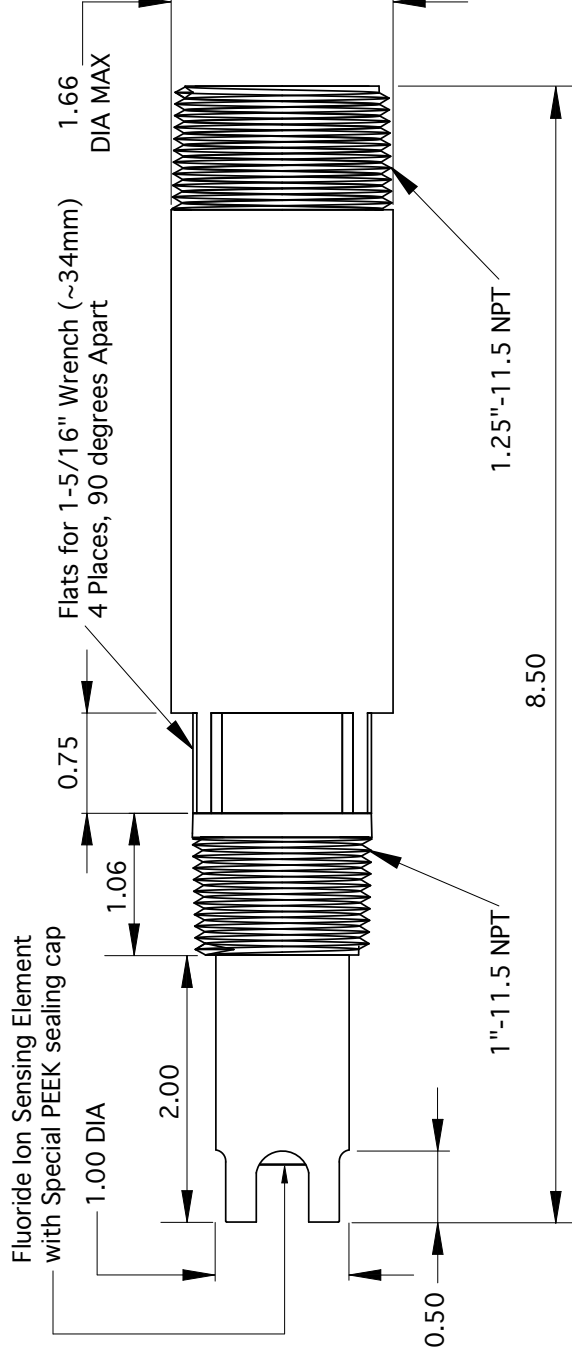

NOTES

1. All dimensions are in inches with tolerances as detailed below
2. Sensor body material of construction is RADEL for special AB 6100 fluoride ion selective ISE sensor
3. Support matrix for solid-state cross-linked conductive polymer reference is HDPE material of construction
4. Drawing shown in the standard with protective tines configuration (4 places, 90 degrees apart).
5. The 2 protective tines only "GRO" configuration (2 places, 180 degrees apart) is optional.
6. In the alternate without tines configuration ("NG") the sensor body is exactly 8.0 inches in length.
7. AB 6100 is the ONLY model suitable for use in acid process media and to endure strong acid cleaning for immersion or submersible style installations.
8. Note suitable for inline use. Only designed and supported for immersion or submersible style installations.
9. Available in configurations with & without preamplifier Terminations are tinned leads or Q7M Snap Connector
10. Do not use any sensor beyond the factory defined maximum temperature or pressure rating.



ASTI Advanced Sensor Technologies U.S.A.
Website: <http://www.astisensor.com>

TITLE		1"-1.25" MNPT Inline / Immersion / Submersible	
SIZE	PROJECT	DRAWING NO.	REV
B	Use in Acid Acid Clean	F-1-ISE Ion Selective Sensor	/
SCALE		MODEL	SHEET
Not to Scale		AB 6100 Fluoride ISE	1 OF 1

2

1

3

1

2

3

REVISION HISTORY			
REV	DESCRIPTION	DATE	APPROVED

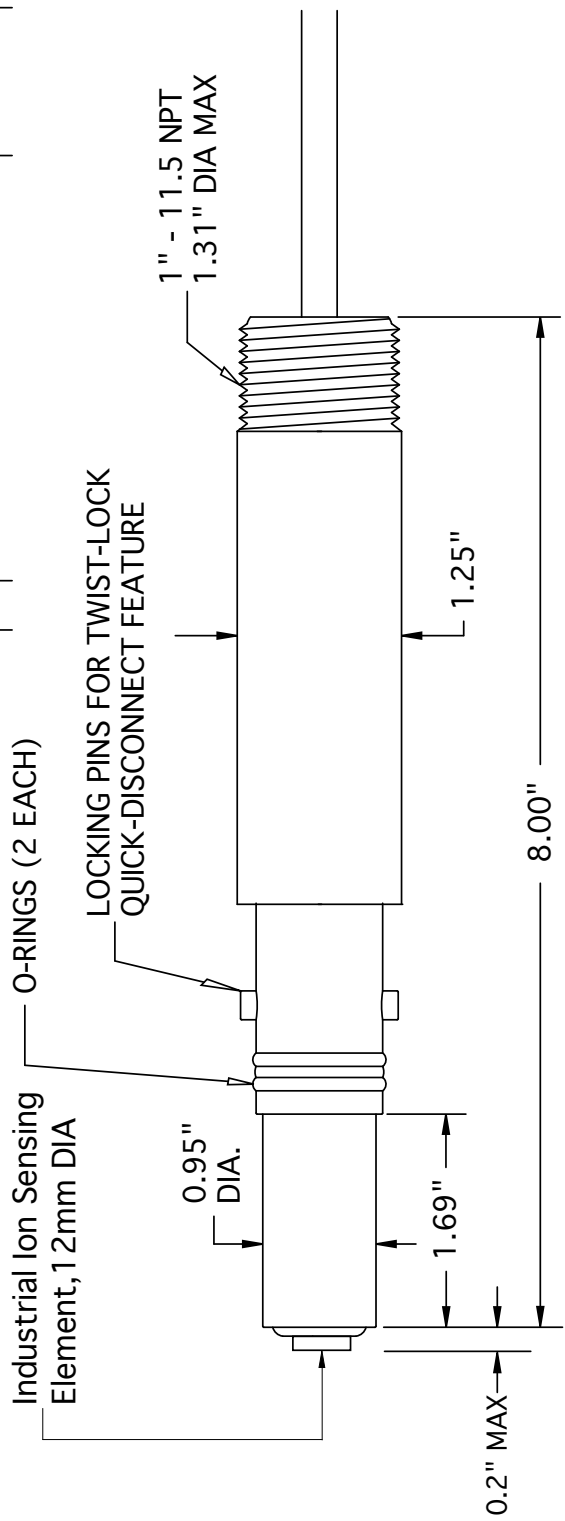

A

A

NOTES

1. All dimensions are in inches, unless otherwise indicated with tolerances as detailed below
2. Sensor body material of construction is RADEL for all 8XX0 series ion selective (ISE) models
3. O-ring material of construction is Viton-75 standard; CV75, Simriz 485 & Kalrez 4079 Optional
4. Drawing as shown is without protective tines. The maximum displacement of the sensor past the end of the body in this configuration is 0.2" inches yielding a max overall length of 8.2 inches.
5. With Protective tines "GR" (4 places, 90 degrees apart) or "GRO" (2 places, 180 degrees apart) configurations overall sensor length is 8.00 inches.
6. This sensor is only suitable for inline installation when used with ASTI 1" MNPT Twist Lock Receptacle.
7. Do not use any sensor beyond the factory defined maximum temperature or pressure rating.

B

B



Advanced Sensor Technologies U.S.A.
Website: <http://www.astisensor.com>

TITLE			
Sensor for Inline Twist Lock Quick Disconnect Use			
SIZE	PROJECT	DRAWING NO.	REV
B	TWIST-LOCK	8-ISE Ion Selective Sensor	/
SCALE		MODEL	SHEET
Not to Scale		8XX0	1 OF 1

2

3

1

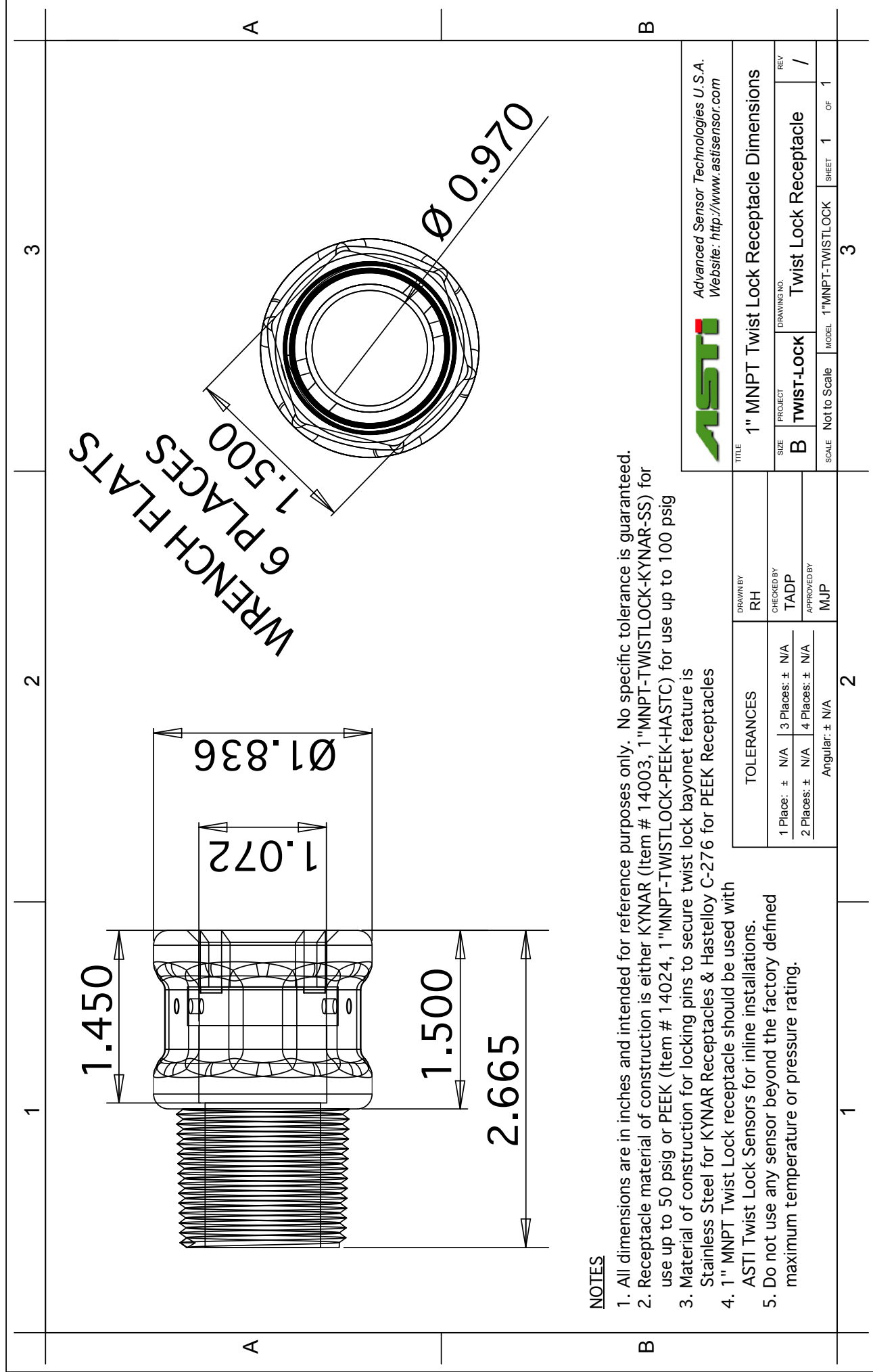

NOTES

1. All dimensions are in inches and intended for reference purposes only. No specific tolerance is guaranteed.
2. Receptacle material of construction is either KYNAR (Item # 14003, 1"MNPT-TWISTLOCK-KYNAR-SS) for use up to 50 psig or PEEK (Item # 14024, 1"MNPT-TWISTLOCK-PEEK-HASTC) for use up to 100 psig
3. Material of construction for locking pins to secure twist lock bayonet feature is Stainless Steel for KYNAR Receptacles & Hastelloy C-276 for PEEK Receptacles
4. 1" MNPT Twist Lock Receptacle should be used with
ASTI Twist Lock Sensors for inline installations.
5. Do not use any sensor beyond the factory defined maximum temperature or pressure rating.



Advanced Sensor Technologies U.S.A.
Website: <http://www.astisensor.com>

TITLE		1" MNPT Twist Lock Receptacle Dimensions	
PROJECT	DRAWING NO.	REV	
B TWIST-LOCK	Twist Lock Receptacle	/	
SCALE	MODEL	SHEET	OF
Not to Scale	1"MNPT-TWISTLOCK	1	1

3

2

1

A

B

A

B

3

2

1

1

2

3

REVISION HISTORY		
REV	DESCRIPTION	DATE

For end of cable terminations and wiring detail please see spec sheet

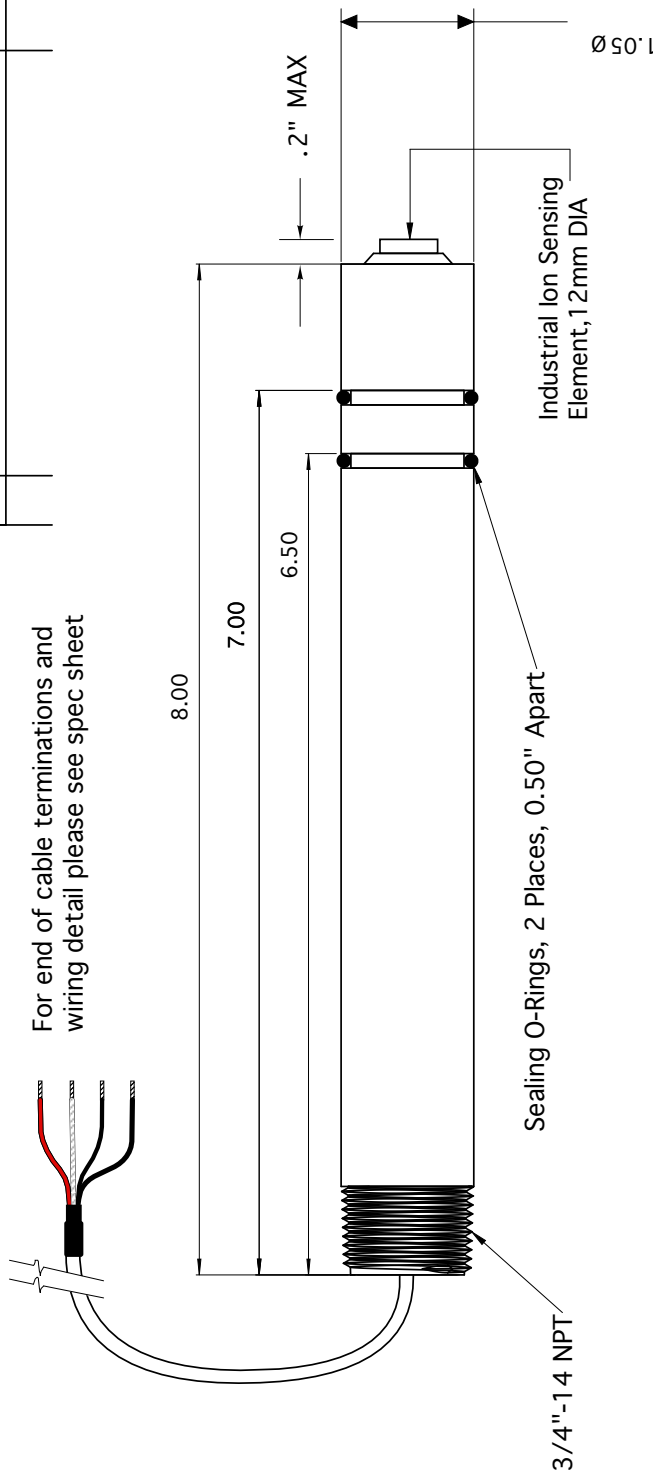

NOTES

- All dimensions are in inches, unless otherwise indicated with tolerances as detailed below
- Sensor body material of construction is RADEL for all 5XX0 series ion selective (ISE) models
- O-ring material of construction is Viton-75 standard; CV75, Simriz 485 & Kalrez 4079 Optional
- Drawing shown without protective tines. The maximum displacement of the sensor past the end of the body in this configuration is 0.2" inches yielding a max overall length of 8.2 inches.
- With Protective tines "GR" (4 places, 90 degrees apart) or "GRO" (2 places, 180 degrees apart) configurations overall sensor length is 8.00 inches.
- This sensor is only for use with ASTI supplied sanitary and valve retractable sensor holders.
- See installation procedures for proper insertion of this sensor into the mating holder.

ASTI Advanced Sensor Technologies U.S.A.
 Website: <http://www.astisensor.com>

TITLE		Sensor for Sanitary & HOT-TAP/Retractable Use	
SIZE	PROJECT	DRAWING NO.	REV
B	SAN / VR	5-ISE Ion Selective Sensor	/
SCALE		MODEL	SHEET
Not to Scale		5XX0	1 OF 1

3

2

1

1 2 3

REV	DESCRIPTION	DATE	APPROVED

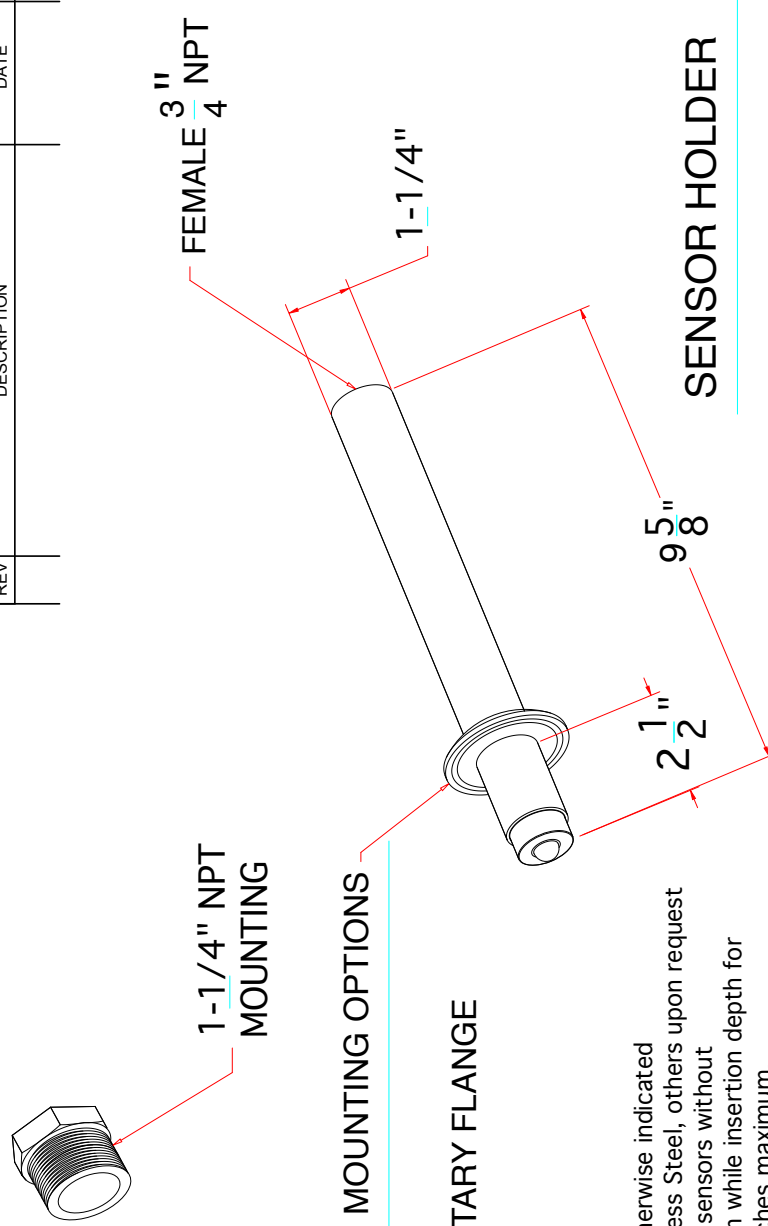

NOTES

- All dimensions are in inches, unless otherwise indicated
- Material of construction is 316L Stainless Steel, others upon request
- Insertion depth past welded fitting for sensors without protective tines is 2.8 inches maximum while insertion depth for sensors with protective tines is 2.5 inches maximum.
- While the insertion depths are described in note # 3 is standard, custom insertion depths are available upon request by modifying the location of the welded fitting (inquire to factory)
- Waterproof sealing assembly on back of sensor holder is not shown above. This consists of a 316L SS 3/4"x1/2" NPT reducer busing with 1/2" MNPT sealing cable gland. This waterproof sealing assy adds about 3 inches to the overall holder length.
- When sensor holder is to be for valve retractable HOT-TAP installation use, no fitting is welded at all.
- Only use with ASTI 5X31, 5X41 & 5XX0 series sensors. See installation procedures for proper insertion.

		Advanced Sensor Technologies, Inc. Orange, California USA Toll-Free: 888-969-2784	
Sensor Holder for Sanitary & HOT-TAP Use			
TITLE Sensor Holder for Sanitary & HOT-TAP Use	PROJECT SAN / VR	DRAWING NO. Sensor Holder Universal	REV /
SIZE B	SCALE Not to Scale	MODEL Various	SHEET 1 OF 1

TOLERANCES	DRAWN BY	APPROVED BY
1 Place: ± .1	RH	TADP
2 Places: ± .01		MJP
3 Places: ± .005		
4 Places: ± .0005		
Angular: ± 0.25°		

3

2

1

Installation Details for 1"MNPT KYNAR® PVDF and KETASPIRE® PEEK Twist Lock Receptacles for Quick Disconnect Bayonet Inline Use

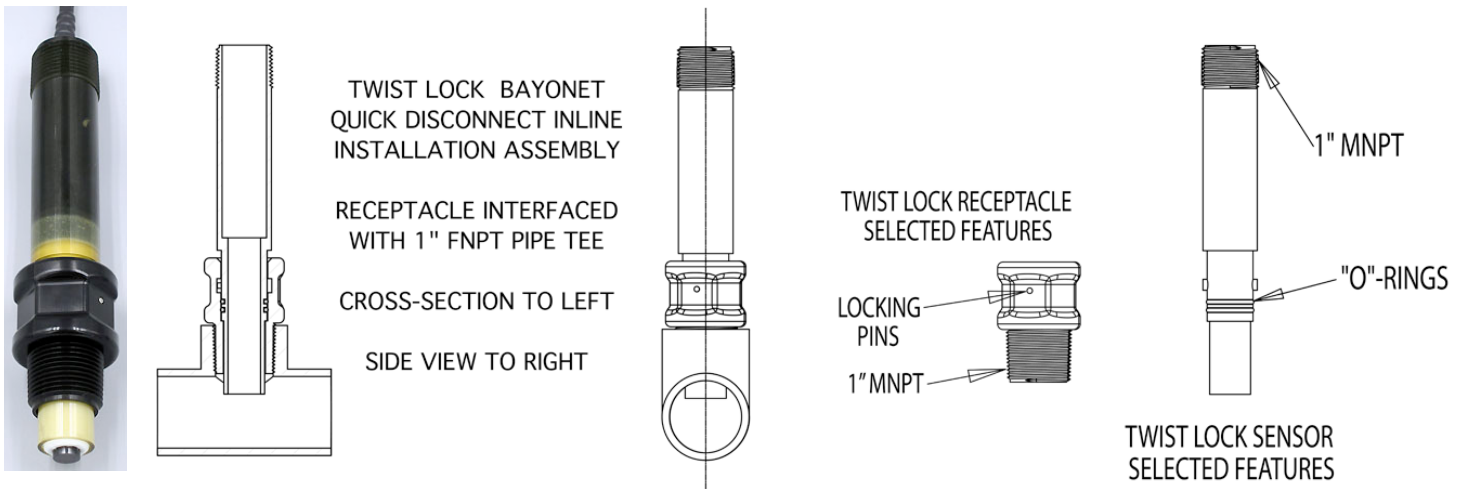

1"MNPT KYNAR® PVDF and KETASPIRE® PEEK Twist Lock Receptacles for Quick Disconnect Inline Installation

PEEK receptacle on left & KYNAR receptacle on right

Please carefully check the recommend maximum temperature and pressure rating of your twist lock sensor prior to installation. Note that the max pressure rating for each twist lock sensor may be dependent upon whether it is used with the KYNAR® PVDF or KETASPIRE® PEEK twist lock receptacle.

Materials of Construction of Ion Selective Sensor Bodies & 1"MNPT Twist Lock Receptacles for Bayonet Style Quick Disconnect Inline Installations

Body Housing RADEL®
Poly-Phenyl-Sulfone, PPSU
Grade R-5000 NT

KYNAR® for 1"MNPT Twist Lock Receptacles & Special Order Type Reference Junction Configurations (Poly-Vinylidene-Fluoride, PVDF)

KETASPIRE®
1"MNPT Twist Lock Receptacles
Poly-Ether-Ether-Ketone, PEEK
Grade KT-880 NT

6XX0, 8XX0 & 5XX0 Ion
Selective (ISE) Sensors

HDPE (High-Density Polyethylene) material of construction is used for most support matrix on solid-state reference systems in ISE sensors

Only required for special inline installation situations. Inquire to factory.

® RADEL and KETASPIRE are registered trademarks of SOLVAY

® KYNAR is a registered trademark of ARKEMA



Industrial Ion Selective (ISE) Sensor Selection Guide

SOLID-STATE TYPE ION SELECTIVE ISE SENSORS	¾"-1" MNPT IMMERSION AB 6XX0 ISE SENSORS	1" MNPT TWIST-LOCK AB 8XX0 ISE SENSORS	SANITARY / HOT-TAP AB 5XX0 ISE SENSORS
<i>Fluoride (F⁻) SPECIAL CONFIGURATION * for Acid / Etching & WWT</i>	AB 6100	Not Available	Not Available
<i>Fluoride (F⁻) for Water Quality & Fluoridation</i>	AB 6100H	AB 8100	AB 5100
<i>Chloride (Cl⁻)</i>	AB 6110	AB 8110	AB 5110
<i>Bromide (Br⁻)</i>	AB 6130	AB 8130	AB 5130
<i>Iodide (I⁻)</i>	AB 6140	AB 8140	AB 5140
<i>Cyanide (CN⁻)</i>	AB 6160	AB 8160	AB 5160
<i>Silver (Ag⁺)</i>	AB 6170	AB 8170	AB 5170

* AB 6100 Special Fluoride (F⁻) ion selective (ISE) sensor is only available in 1"-1.25" MNPT Immersion/Submersible Style Configuration & Installation Scheme

ORGANIC PVC TYPE ION SELECTIVE ISE SENSORS	¾"-1" MNPT IMMERSION AB 6XX0 ISE SENSORS	1" MNPT TWIST-LOCK AB 8XX0 ISE SENSORS	SANITARY / HOT-TAP AB 5XX0 ISE SENSORS
<i>Ammonium (NH₄⁺)</i>	AB 6410	AB 8410	AB 5410
<i>Sodium (Na⁺)</i>	AB 6430	AB 8430	AB 5430
<i>Calcium (Ca²⁺)</i>	AB 6440	AB 8440	AB 5440
<i>Lithium (Li⁺)</i>	AB 6490	AB 8490	AB 5490
<i>Chloride (Cl⁻)</i>	AB 6610	AB 8610	AB 5610
<i>Nitrate (NO₃⁻)</i>	AB 6810	AB 8810	AB 5810
<i>Nitrite (NO₂⁻)</i>	AB 6820	AB 8820	AB 5820

NOTES: Sensor Body Housing is RADEL® (Poly-Phenyl-Sulfone, PPSU) material of construction for all 6XX0, 8XX0 and 5XX0 series ion selective sensors. Primary reference junction support matrix for solid-state non-porous conductive polymer proprietary reference system in HDPE (High-Density-Poly-Ethylene) with KYNAR® (Poly-Vinylidene-Fluoride, PVDF) available as a special-order option for selected configurations.

Ion Selective (ISE) Sensor Options

- All 6XX0 immersion series ion selective (ISE) sensors are supplied standard (default) in the four (4) each protective tines ("GR") configuration. The number of protective tines can be reduced to the 2 each ("GRO") configuration or the guard feature removed altogether ("NG").
 - The reduction to 2 protective tines type guard (or else no guard at all) is sometimes desirable for ease of cleaning, particularly in heavy slurry and high viscous media process media applications as well as cases where air bubbles may be entrenched on the sensing tip for low-flow inline installations.
- All 8XX0 twist lock series ion selective (ISE) and 5XX0 sanitary/HOT-TAP style ion selective (ISE) sensors are supplied without tines (no guard) as the standard default configuration. Four (4) each protective tines ("GR") or 2 each protective tines ("GRO") available as optional configuration.
 - Protective tines for these sensor configurations are machined into the sensor body itself thereby shortening overall sensor length for these optional with protective tines style for the 8XX0 twist lock and 5XX0 sanitary/HOT-TAP series ISE probes.
- Fast temperature compensation response may be desired for some installations with variable temperature conditions (Iotron™ ACCU-TEMP™).
 - The ACCU-TEMP™ ("X") option is recommended for most Twist Lock and Sanitary/HOT-TAP inline installations for best temperature compensation as well as for immersion and submersible installations where the sensor will be frequently removed from service for cleaning and recalibration
- All inline, immersion, twist lock and sanitary/HOT-TAP ISE sensors can have the waterproofing option added for submersible sensor installations. See next page to visualize an ion selective sensor with a waterproofing "B" option installed for fully submersible installation with the use of an immersion rod.
- All ISE sensor configurations may be mounted from rear using the available 3/4" or 1" MNPT threads for immersion installations when used with a suitable mating insertion tube, standpipe or guide rod.
 - For fully submersible installation a waterproofing option is recommended for best sensor longevity.
 - Sensors employed for immersion or submersible style installations should have a with protective tines (with guard) configuration to minimize possibility of accidental breakage during handling and/or field use.
- The immersion and twist lock series ISE sensors can also be installed with a variable insertion depth into a process line or tank using a compression fitting only scheme employing an extension tube.
- Sensors with integral preamplifiers can be supplied with the rugged field ready Q7M/Q7F NEMA 6P rated quick disconnect snap connector system. See next page for visualization of this connector option.

APPENDIX "A"

Custom Applications

	<u>Alpha Prefix</u>
Dissolved Gas Resistant	"A" or "C"
Organic Media Applications*	"L"
Teflon Silicone Required*	"TS"
Triple Junction*	"TJ"
Extreme Dehydration Resistant*	"E"

Custom Configurations

	<u>Alpha Prefix</u>
ACCU-TEMP™ Option for Fast Temperature Response*	"X"
No guard configuration option (for 6XX0 immersion ISE sensors)	"NG"
Add 4 each Protective Tines (for 8XX0 twist lock & 5XX0 sanitary & HOT-TAP ISE sensors)*	"GR"
Add/Reduce to 2 each Protective Tines (for all 6XX0/8XX0/5XX0 ISE sensors)*	"GRO"
Shielded & Reinforced Preamplifier Blue Cable (for all 6XX0/8XX0/5XX0 ISE sensor series)*	"BL"
Upgrade from standard Viton® -75 to CV75, Simriz® 485 or Kalrez® 4079*	"W", "U" or "K" respectively

*** Additional charges may apply for these options. Not all options available on all models & not all combination of options are compatible (inquire to factory).**

® Viton and Kalrez are registered trademarks of DuPont. Simriz is a registered trademark of Freudenberg Sealing Technologies (SIMRIT).

Photos for Visualization of Selected Industrial Ion Selective (ISE) Sensor Options



Q7M sensor end of cable snap connector detail close-up view.



AB 6100 fluoride ion selective submersible sensor with integral preamplifier; WPH waterproofing option & Q7M NEMA6P rated snap connector for use with Q7F-Xm-TL female snap to tinned lead extension cables



Q7F-Xm-TL Female snap to tinned leads extension cable



Q7M/Q7F connectors are NEMA 6P rated when properly interfaced (protective boots are supplied when not in use).



Rear view of waterproofing "B" sealing option for AB 8XX0 series fully submersible ion selective sensor



Typical Immersion Style Ammonium Ion Selective & pH Sensor for Municipal Wastewater Treatment Facilities. Both sensors are required to continuously measure total ammonia.



Typical Immersion Style Fluoride Ion Selective & High HF Resistant pH Sensor for use in acid etching processes and fluoride wastewater treatment (WWT) plants. Both fluoride ISE & pH sensors required to continuously measure total fluoride species.

Please inquire to factory for any options or configuration that are not detailed in this document as they may be available on a special order custom basis. Minimum Order Quantity (MOQ) may apply for some special-order situations.

Last Revised 2017-05-20