



# IOTRON™ SENSORS

## INTEGRATED ORP SENSOR SPECIFICATIONS

<u>Part Number:</u>	PNS 6831
<u>Configuration:</u>	2 1/2" O.D. Integrated Sanitary, ORP Sensor
<u>General Specifications:</u>	
<u>mV Range:</u>	-2000 to +2000 mV
<u>Temperature Range:</u>	-5 to 105 °C
<u>Pressure Range:</u>	1 to 100 psia (6.9 to 690 kPa absolute)
<u>Body Material:</u>	Ultem (Poly-Ether-Imide)
<u>Junction Material:</u>	Kynar (Poly-Vinylidene-Fluoride)
<u>Dimensions:</u>	Drawing <6-7 PT>
<u>Cable:</u>	RG 174/U Coaxial (without preamplifier)
<u>Connector:</u>	BNC (unless otherwise specified)
<u>ORP Sensor Specifications:</u>	
<u>Measuring Glass Type:</u>	Hemispherical Glass with high purity Pt band
<u>Dimensions:</u>	0.310/0.185, (7.8/4.7 mm) DIA
<u>Reference System Specifications:</u>	
<u>Type:</u>	Double Junction
<u>Reference Half Cell:</u>	Ag/AgCl, Saturated KCl
<u>Primary Junction:</u>	Porous Ceramic, Saturated with KCl in crosslinked polymer
<u>Secondary Junction:</u>	Porous Kynar, Saturated with KCl in crosslinked polymer
<u>Surface Area:</u>	366,000 mil <sup>2</sup> (236 mm <sup>2</sup> )
<u>Special Features:</u>	Crosslinked polymer is resistant to heat, solvents and to most chemicals. Sensor holds an excess of KCl, assuring saturation at all temperatures and extending in situ sensor life. The reference system holds a generous supply of aqueous saturated KCl, eliminating effects of intruding contaminants and permits the sensor to be left in dry condition for extended periods of time.
<u>Recommended Applications:</u>	Plating baths, plating wastewater treatment, chemical processes, pollution control, measurements where long service life or operation at remote locations where (no) low maintenance is required.
<u>Storage and Shelf Life:</u>	At room temperature with closed protector cap, 1 year from date of manufacture.
<u>Standard Hook-Up Options:</u>	No Preamp - BNC Connector + TC lead wires With Preamp – Multiconductor Lead Wires – See Hook Up Schematics

REVISIONS		
ZONE	REV	DATE
2	1	

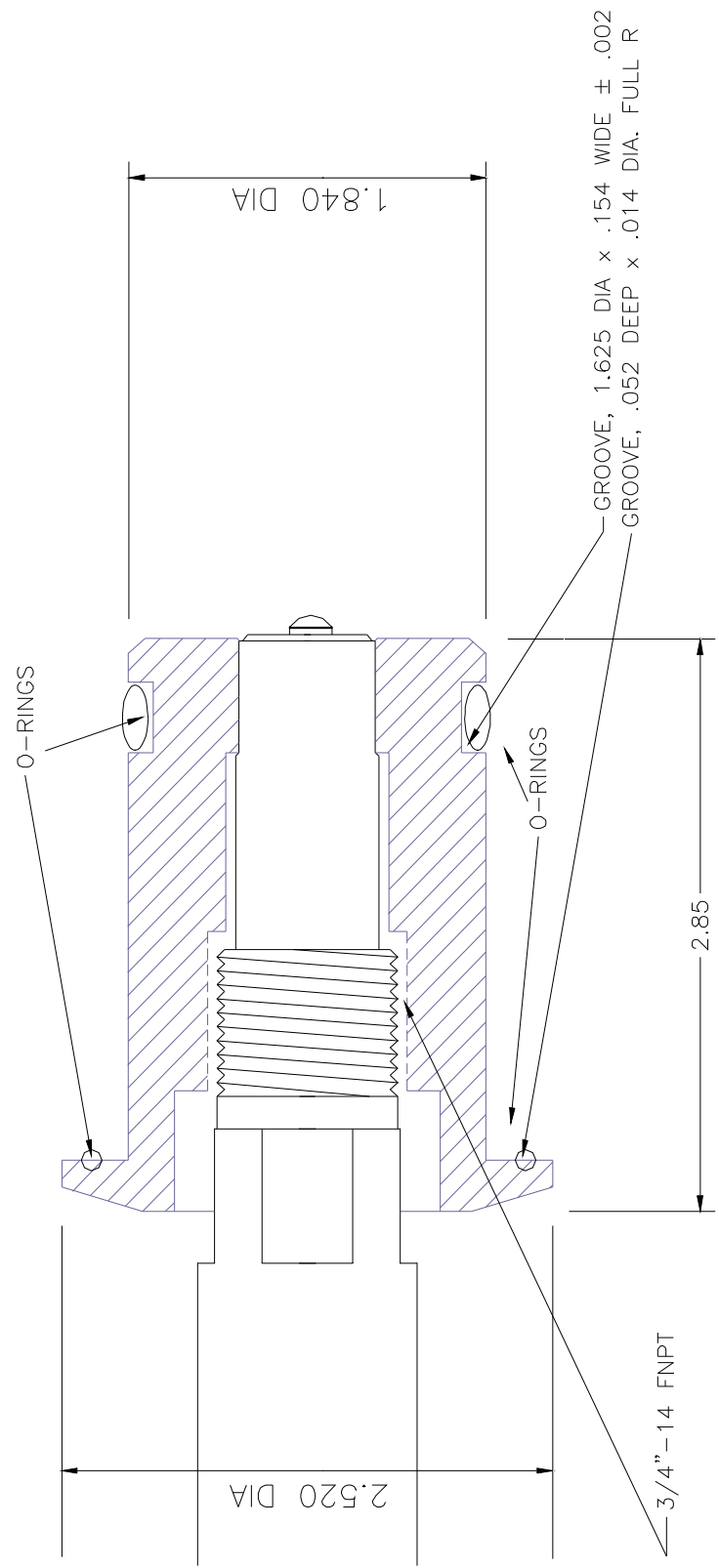

<b>ASTI</b> Advanced Sensor Technologies, Inc.	
SANITARY ORP SENSOR	
REF. DRAWING <6-7-Plt>	
SIZE	FORM NO.
2	<6-7>-Plt
DWG NO.	REV
ASTI6631.DWG	1
DRAWN BY: PETE CSISZAR	
SCALE: NONE	DATE: MARCH, 2003
SHEET 1	OF 1

1 2 3 4

D C B A

1 2 3 4